



TECHNICAL GUIDANCE

NEW GENERATION OF TORQUE TUBE

FST4000 Series

DISPLACER TYPE LEVEL TRANSMITTER

GENERAL

FST4000 is a torque tube displacement type level indicating transmitter with intelligent data processing function. Through 18 years of field proven experiences accumulated by the existing model FST-3000, FST4000 has intensified its reliability by adding such features as SIL2 compatible functional safety, ATEX flameproof and field bus communication of FOUNDATION Fieldbus.

Varieties of materials and wide range of pressure ratings are available to meet various applications such as high pressure and temperature boilers as well as low temperature down to minus 196°C of liquefied gases.

STANDARD SPECIFICATION

- 1) Detection method : Torque tube type displacer
- 2) Measuring range : Min. 0 to 300 mm, Max. 0 to 3000 mm
- 3) Liquid density
 - ① Level measurement : 0.2 to 1.5 g/cm³
 - ② Interface measurement : Density difference between 2 liquids is more than 0.1 g/cm³
 - ③ Density measurement : Min. density span is 0.2 g/cm³
Consult TOKYO KEISO Co. Ltd. for the services not mentioned above.
- 4) Available pressure class : ASME class 150, 300, 600, 1500 and 2500
- 5) Fluid temperature range : -196 to +450 °C
- 6) Installation : Tank top or tank side installation
- 7) Connection size : External chamber type : 1-1/2 or 2 inch flange Internal chamber type : 3 or 4 inch flange See Fig.2 and Fig.3.
- 8) Ambient temperature : -40 to +70 °C during operation
Allowable temperature is subject to the applicable explosionproof standards.
: -45 to +80 °C during storage
- 9) Ambient humidity : 0 to 95 % R.H. during operation
: 0 to 85 %R.H. during storage
- 10) Available material
 - ① Torque tube : SUS316L, NW0276, NCF600, MONEL
 - ② Bonnet : SCPH2, SCS13A, SCS14A, SCS16A, NW0276
 - ③ Chamber : Carbon steel, SUS304, SUS316, SUS316L, NW0276
 - ④ Displacer : SUS304, SUS316, SUS316L, NW0276, MONEL, PVC, Others
 - ⑤ Transmitter housing : ADC12
- 11) Local indication : LCD display
Line 1 Function indication in 4 digits
Line 2 Data indication in 4 digits
Line 3 Bar graph in percent
- 12) Output, Power supply, Communication
 - Output 4 to 20 mA DC, 2 wire system with HART (version 6)
 - Supply voltage (UB) and Max. Load (Ra)
UB : 8 to 40 VDC
Max. load (Ra) : Ra = (UB - 8 V)/0.0248 A (Ω)
4 to 20 mA DC signal : conforms to NAMUR NE43
Operating range : 3.9 to 20.5 mA DC
Burn-out : The output is selectable from "less than 3.5 mA" or "more than 21.6 mA" or "remain stationary"



**ATEX
SIL2**

HART, FOUNDATION Fieldbus

- | | | |
|-----------------------------------|---|---|
| Communication | : | |
| HART | : | Version 6 single drop or multi drop (Ra shall be Ra ≥ 250 Ω) |
| • FOUNDATION Fieldbus | : | |
| Supply voltage | : | 9 to 32 VDC *1 |
| Base Current | : | 18 mA DC or less |
| Input and output signals | : | conform to IEC61158-2 |
| Communication protocol | : | FOUNDATION Fieldbus H1 |
| H1 Profile Class | : | 31PS, 32L |
| H1 Device class | : | Link Master |
| Function block | : | 1-RB2, 1-AI, 1-TB |
| *1 | : | When a safety barrier is used in intrinsically safe circuit, the supply voltage is 9 to 24 VDC. FISCO explosionproof 9 to 17.5 VDC |
| 13) Accuracy | : | ±0.5 %F.S (Based on mass conversion correction at factory calibration) |
| 14) Protection class | : | IP67, JIS C0920 equivalent to IEC60529 |
| 15) Explosionproof classification | : | |
| ① Flameproof | : | TIIS Exd II CT6
ATEX & IECEx Exd II CT6...T1 *2
KOSHA, NEPSI |
| ② Intrinsically safe | : | ATEX & IECEx Ex ia II CT6...T1 *2
KOSHA, NEPSI |
| *2 | : | Refer to instruction manual |
| 16) Cable entry | : | G1/2, 1/2NPT, M20 x P1.5 |
| 17) Painting | : | Transmitter Munsell 7.5BG4/1.5
Chamber silver
No painting on stainless steel components |
| 18) Related standards referred: | : | ATEX (IEC60079-0, -1, -11)
EMC (IEC61000-4-2 to-4-6, IEC61010-1, IEC61326-2-1, EN5501), TIIS, PED |
| 19) Functional safety | : | SIL2 compatible with IEC61508 |
| 20) RoHS Directive | : | Complied with |
| 21) Product mass | : | Pressure rating class 150 approx. 30kg
Pressure rating class 600 approx. 35kg |
| 22) Setting | : | Following operation and settings are available either remotely through HART or locally by the magnet key operation. Zero adjustment, Span adjustment, Output simulation test, Damping adjustment, Setting of burn-out, Density. |

MODEL CODE

FST4										DESCRIPTION	
Measuring range	1			-						300 mm or less	
	2			-						301 to 500 mm inclusive	
	3			-						501 to 700 mm inclusive	
	4			-						701 to 1000 mm inclusive	
	5			-						1001 to 1500 mm inclusive	
	6			-						1501 to 2000 mm inclusive	
	7			-						2001 to 2500 mm inclusive	
	8			-						2501 to 3000 mm inclusive	
	9			-						Special	
Installation method	1			-						SIDE --SIDE	
	2			-						BOTTOM --SIDE	
	3			-						SIDE --TOP	
	4			-						BOTTOM --TOP	
	5			-						Top mount	
	6			-						Side mount	
	9			-						Special	
	Material: Bonnet/ Displacer/ Chamber	1			-						SCPH2 / SUS304 / Carbon steel
		2			-						SCS13A/ SUS304 / SUS304
3				-						SCS14A/ SUS316 / SUS316	
4				-						SCS16A/ SUS316L/ SUS316L	
9				-						Special	
Enclosure				-						General purpose	
	E			-						Flameproof type	
	S			-						Intrinsically safe type	
Pressure rating	1			-						ASME (JPI) Class 150	
	2			-						ASME (JPI) Class 300	
	3			-						ASME (JPI) Class 600	
	4			-						JIS 10K	
	5			-						JIS 30K	
	6			-						JIS 63K	
	7			-						ASME (JPI) Class 1500	
	8			-						ASME (JPI) Class 2500	
	9			-						Special	
Process connection	1			-						1-1/2 inch flange	
	2			-						2 inch flange	
	3			-						3, 4 inch flange (used only for the installation "5" top mount)	
	9			-						Special	
Torque tube material	1			-						SUS316L -196 to 200°C	
	2			-						INCONEL -196 to 450°C	
	3			-						NW0276 -196 to 200°C	
	9			-						Special	
Cable entry	1			-						G1/2(F)	
	2			-						1/2NPT (F)	
	9			-						Special	
Orientation (rotation angle) Refer to the below diagram.						L1 to L8				Left hand side	
						R1 to R8				Right hand side	
Explosionproof and communication	1									TIIS Flameproof with HART Ex d IIC T6	
	3									ATEX & IECEx Flameproof with HART Exd IIC T6	
	4									ATEX & IECEx Intrinsic safety with HART Ex ia IIC T6	
	5									ATEX & IECEx Flameproof with FOUNDATION Fieldbus Exd IIC T6	
	6									ATEX & IECEx Intrinsic safety with FOUNDATION Fieldbus Exia IIC T6	
	7									KOSHA Flameproof with HART Exd IIC T6	
	8									KOSHA Intrinsic safety with HART Ex ia IIC T6	
	A									NEPSI Flameproof with HART Exd IIC T6	
B									NEPSI Intrinsic safety with HART Ex ia IIC T6		

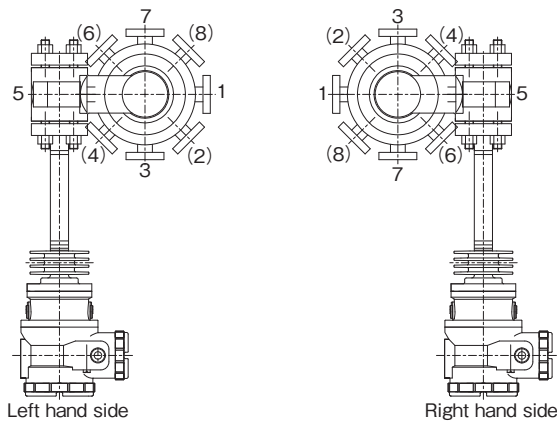

Note: Positions of (2) (4) (6) (8) are not selectable for the pressure rating "1", i.e. ASME class 150.

DIMENSIONS

● Fig.1 Transmitter, Torque Tube & Bonnet

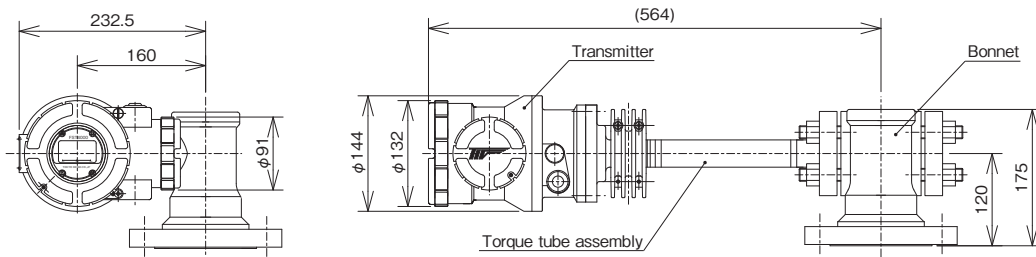

● Fig.2 Assembling of the chamber for class 150 or 300

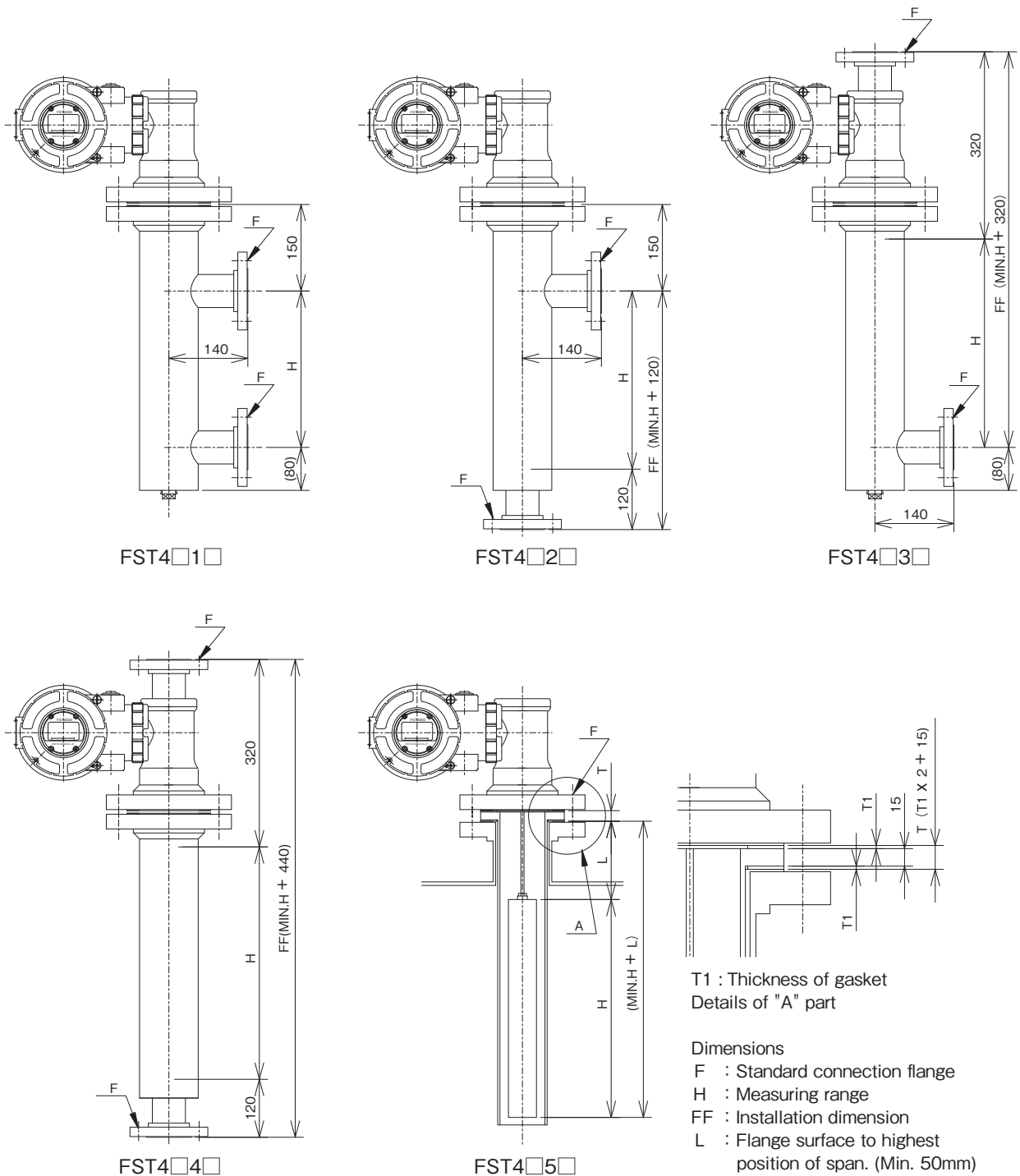

Please specify above dimensions when ordering.

DIMENSIONS

● Fig.3 Assembling of the chamber for class 600 Assembling and mounting dimensions differ with the class 900 and higher classes.

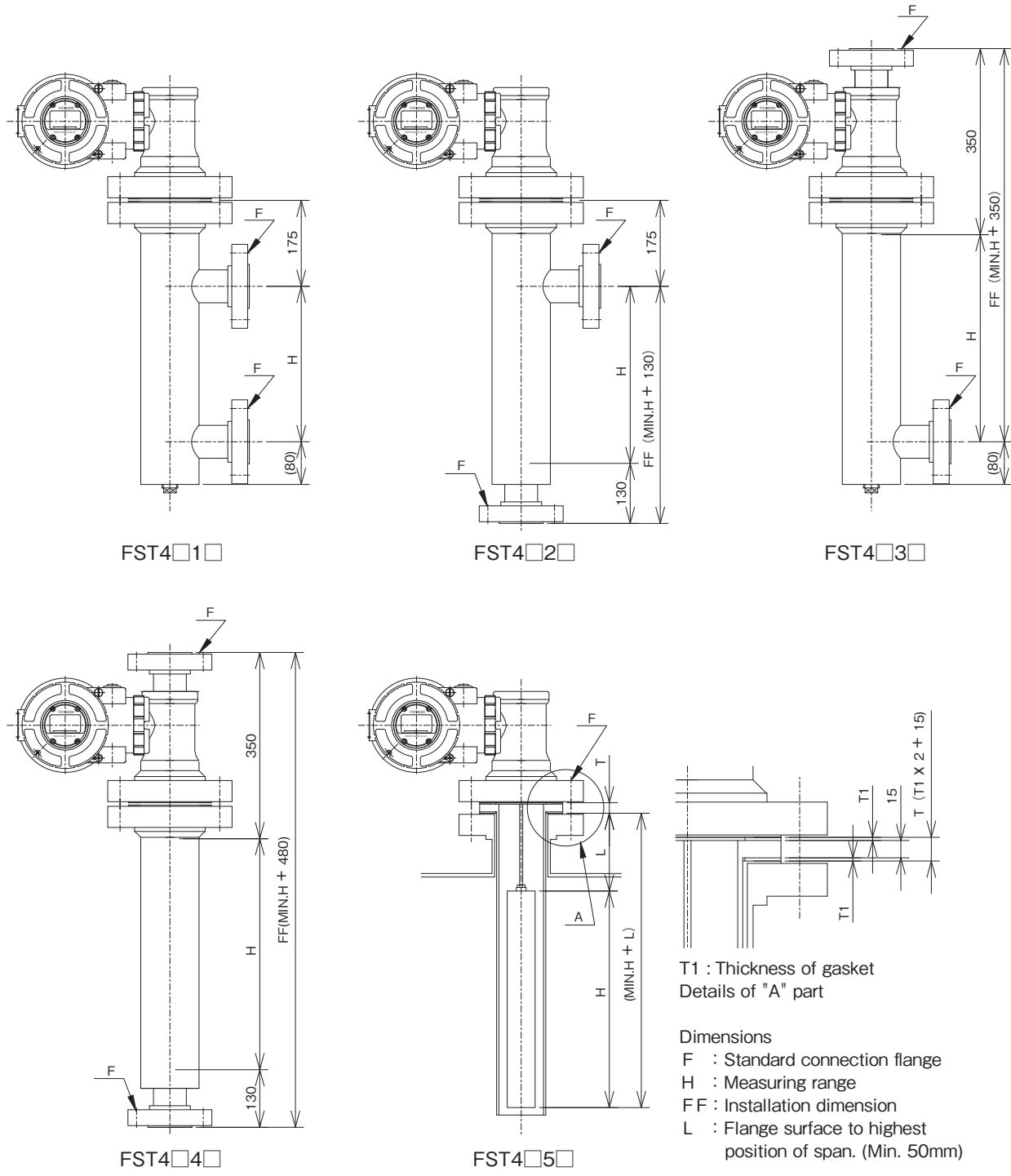

Please specify above dimensions when ordering.

MATERIAL OF GASKET, BOLT & NUT

Code	Gasket	Code	Bolt & Nut	Remarks
1	V#7020	1	SS400	Steel
2	V#8591	2	SUS304	Stainless steel
3	V#8596	3	SNB7 / S45C (A193-B7 / A194-2H)	Carbon steel
4	V#6596	4	A320-L7 / A194-4	Carbon steel, For low temperature services
5	V#7596	5	A193-B8CL2 / A194-8	Stainless steel, For high temperature services
		6	A320-B8CL2 / A194-8	Stainless steel for low temperature services
9	Special	9	Special	

WIRING

● Flameproof version

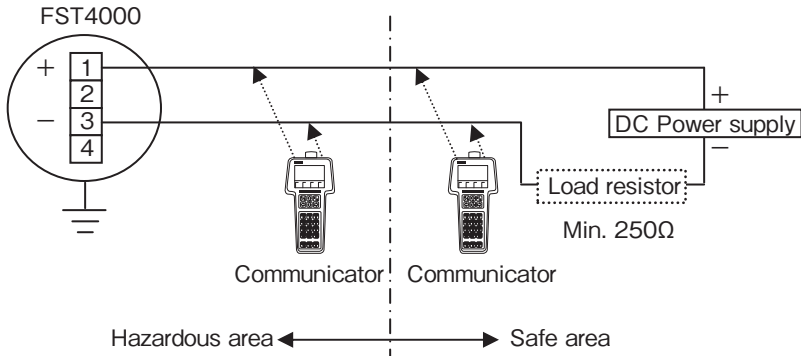

● Intrinsically safe version

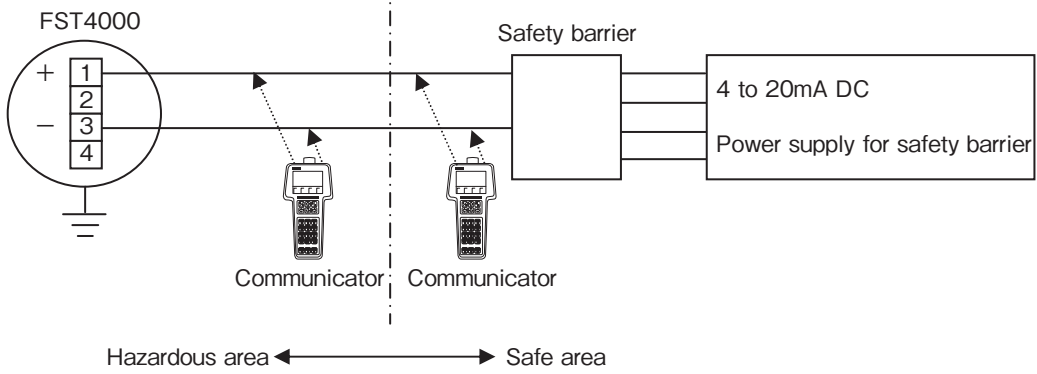

Rating values of intrinsic safety

Maximum Voltage	28V
Maximum Current	93mA
Maximum Wattage	651mW
Internal Inductance	100μH
Internal Capacitance	100nF

● FOUNDATION Fieldbus version

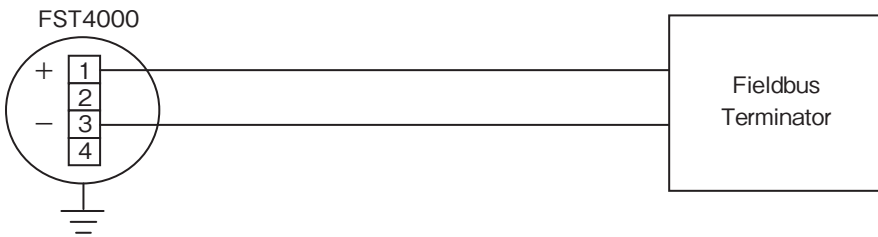

ORDERING INFORMATION

Specify the following for order and inquiry:

1. Model	FST4□□□□-□□□□-□□□			
2. Liquid name				
3. Density				
4. Temperature Nor. Max.	NOR.	MIN.	MAX.	□°C
5. Pressure Nor. Max.	NOR.	MAX.	□MPa	□ ()
6. Connection				
7. Cable entry				
8. Measuring range				
9. Center to center distance				

* Specification is subject to change without notice.



Head Office : Shiba Toho Building, 1-7-24 Shibakoen, Minato-ku, Tokyo 105-8558
 Tel : +81-3-3431-1625 (KEY) ; Fax : +81-3-3433-4922
 e-mail : overseas.sales@tokyokeiso.co.jp ; URL : http://www.tokyokeiso.co.jp